

HDS HYDRAULIC DREDGING SYSTEMS

HYDRAULIC 90 KW / 120 HP DISCHARGE 8 INCH

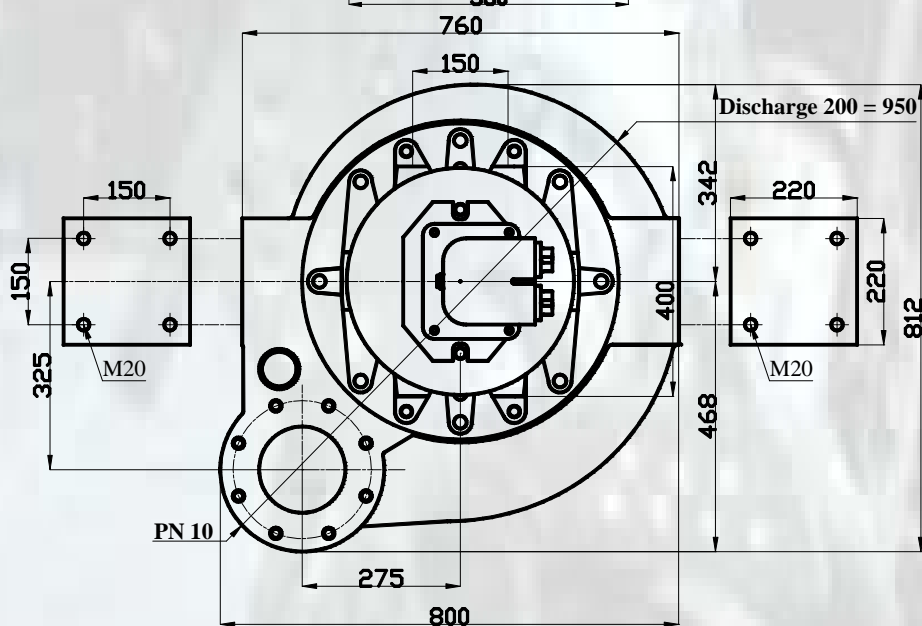
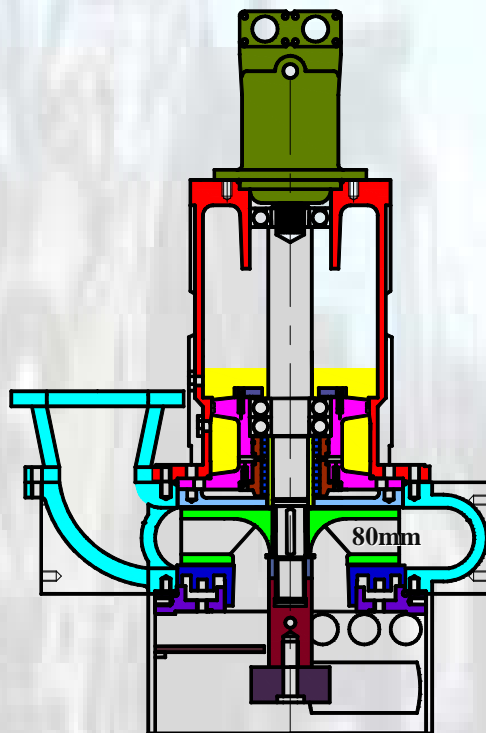
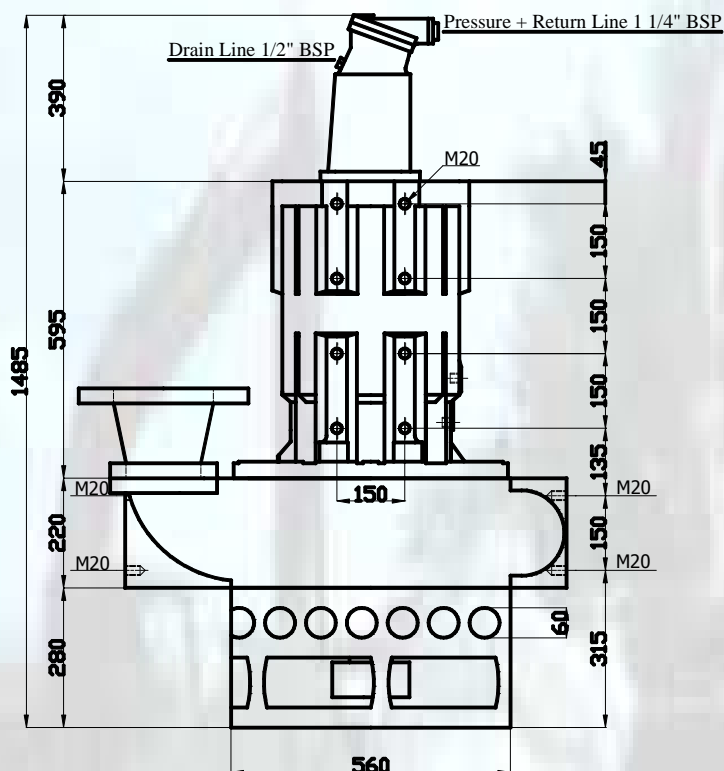

Specifications:

Hydraulic Driven 90 KW 120 HP 1000 RPM
 Oil Supply at 1000 RPM = 175 L/ MIN
 Oil Pressure at 1000 RPM 280 BAR
 Max Pressure 350 BAR
 TORQUE= 2, 56 Nm/BAR

WEAR PARTS CHROM CASTING
 SHAFT 42 CRMo4-DIN 7225-SAE 4140
 EXCAVATOR MOUNTING PADS
 LOWER STRAINER 70 MM

DISCHARGE PIPE 8 INCH 200 mm

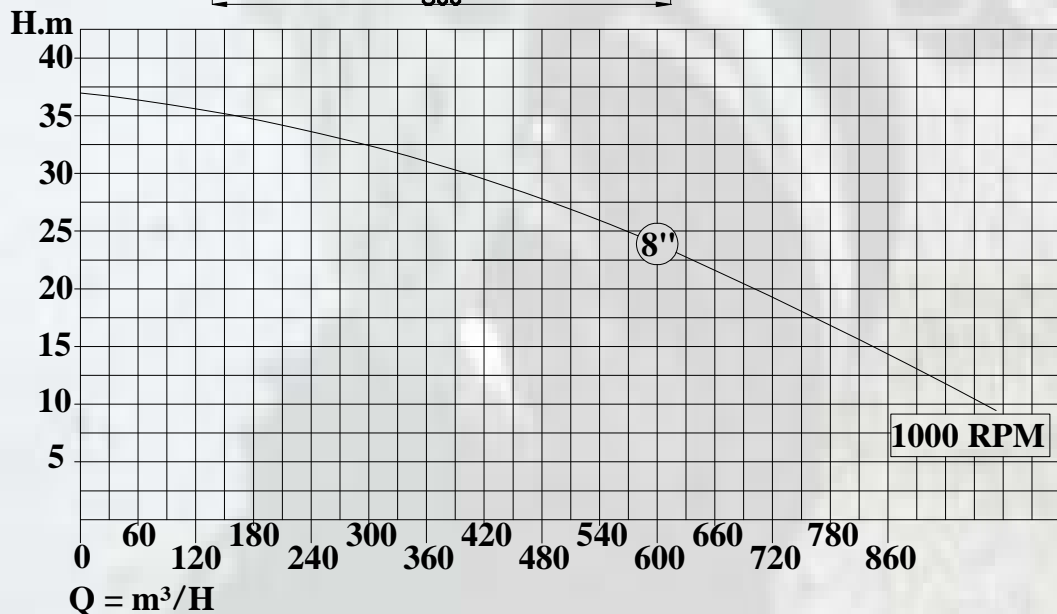

1000RPM
 600 M3/H
 24 M

IMPELLER WIDTH 80mm
 WEIGHT 800 KG