

HDS 125L

Discharge : 200mm / 8 Inch
 Power : 78KW / 106 HP
 Hydraulic 125cc Piston Motor
 Low Speed - Low Wear

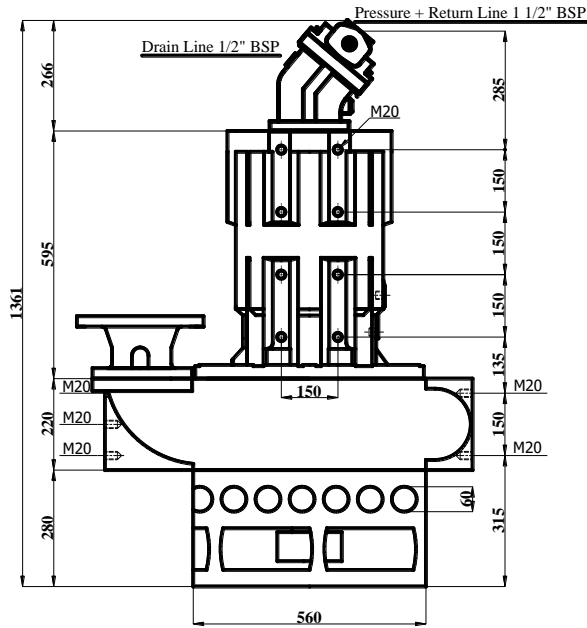

RPM	Q m ³ /h	H meter	KW - HP	Operating Pressure BAR	Oil Flow l/min
1050	500	16	62 - 83	270	140
1200	550	22	78 - 106	300	160

CONTINUOUS DUTY AT LOW SPEEDS
 IMPELLER WIDTH 80mm - STRAINER 60mm
 WEAR PARTS CHROM CASTING 27% Cr
 SHAFT TEMPERED STAINLESS AISI T-431 DIN 1-4057
 TORQUE 2 Nm / BAR
 MOTOR DISPLACEMENT 124,8cc
 MAX CONTINUOUS OIL PRESSURE 430 BAR
 EXCAVATOR MOUNTING PADS
 2C - PAINT
 WEIGHT 830 KG

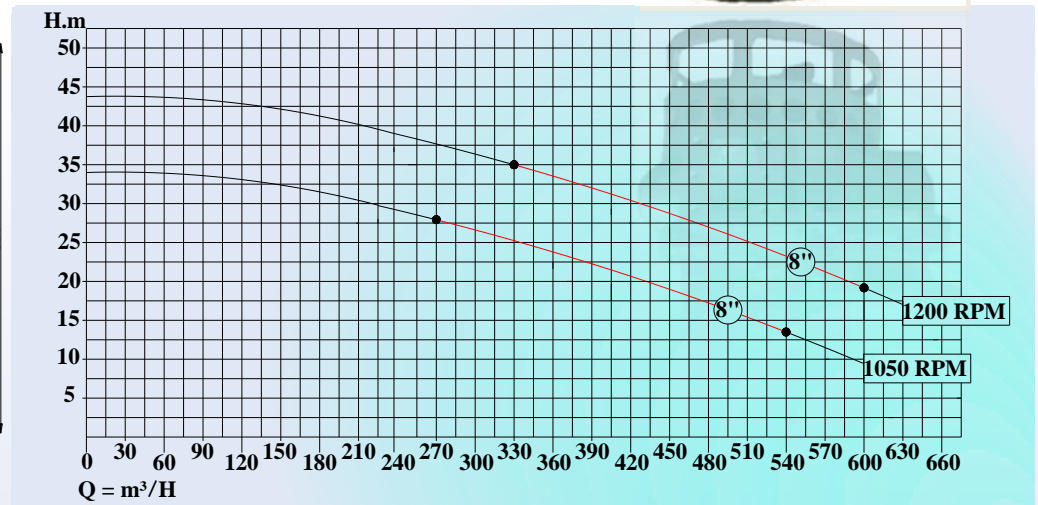
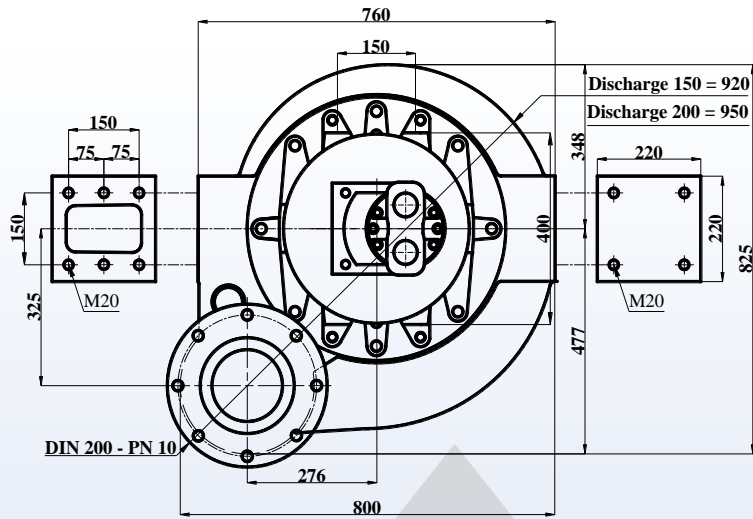
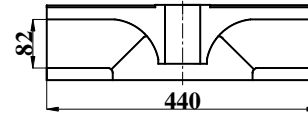

All data are subject to change without prior notice.